

Silicon NPN Power Transistors

BU1507AX

DESCRIPTION

- With TO-220F package
- High voltage
- High speed switching

APPLICATIONS

- For use in horizontal deflection circuits of colour TV receivers and computer monitors.

PINNING

PIN	DESCRIPTION
1	Base
2	Collector
3	Emitter

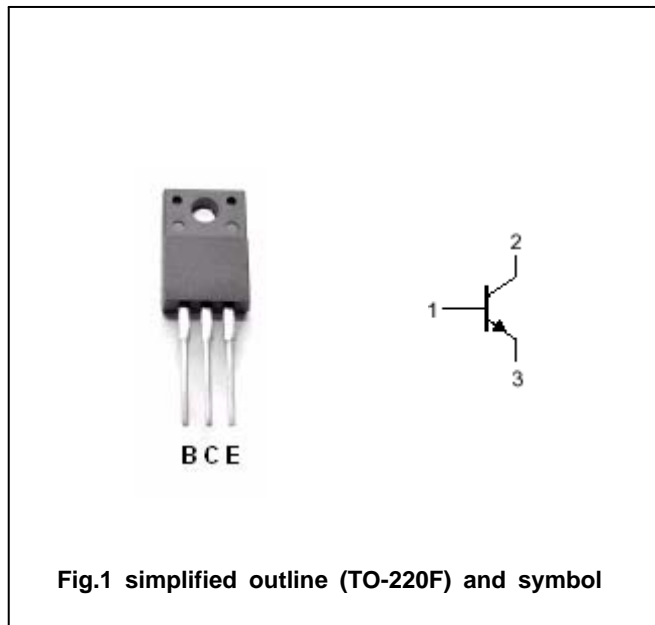

Absolute maximum ratings (Ta=25)

SYMBOL	PARAMETER	CONDITIONS	VALUE	UNIT
V _{CBO}	Collector-base voltage	Open emitter	1500	V
V _{CEO}	Collector-emitter voltage	Open base	700	V
V _{EBO}	Emitter-base voltage	Open collector	7.5	V
I _C	Collector current		8	A
I _{CM}	Collector current (peak)		15	A
I _B	Base current		4	A
I _{BM}	Base current (peak)		6	A
P _T	Total power dissipation	T _C =25	45	W
T _j	Junction temperature		150	
T _{stg}	Storage temperature		-65~150	

Silicon NPN Power Transistors

BU1507AX

CHARACTERISTICS

T_j=25 unless otherwise specified

SYMBOL	PARAMETER	CONDITIONS	MIN	TYP.	MAX	UNIT
V _{(BR)EBO}	Emitter-base breakdown voltage	I _E =1mA ; I _C =0	7.5	13.5		V
V _{CEO(SUS)}	Collector-emitter sustaining voltage	I _C =100mA ; I _B =0; L=25mH	700			V
V _{CEsat}	Collector-emitter saturation voltage	I _C =4A; I _B =0.8A			5.0	V
V _{BEsat}	Base-emitter saturation voltage	I _C =4A; I _B =0.8A			1.1	V
I _{CES}	Collector cut-off current	V _{CE} =rated; V _{BE} =0 T _j =125			1.0 2.0	mA
I _{EBO}	Emitter cut-off current	V _{EB} =7.5V; I _C =0			1.0	mA
h _{FE-1}	DC current gain	I _C =0.1A ; V _{CE} =5V		17		
h _{FE-2}	DC current gain	I _C =4.0A ; V _{CE} =5V	5.0	7.0	9.0	
C _C	Collector output capacitance	I _E =0; f=1MHz; V _{CB} =10V		68		pF

Silicon NPN Power Transistors

BU1507AX

PACKAGE OUTLINE

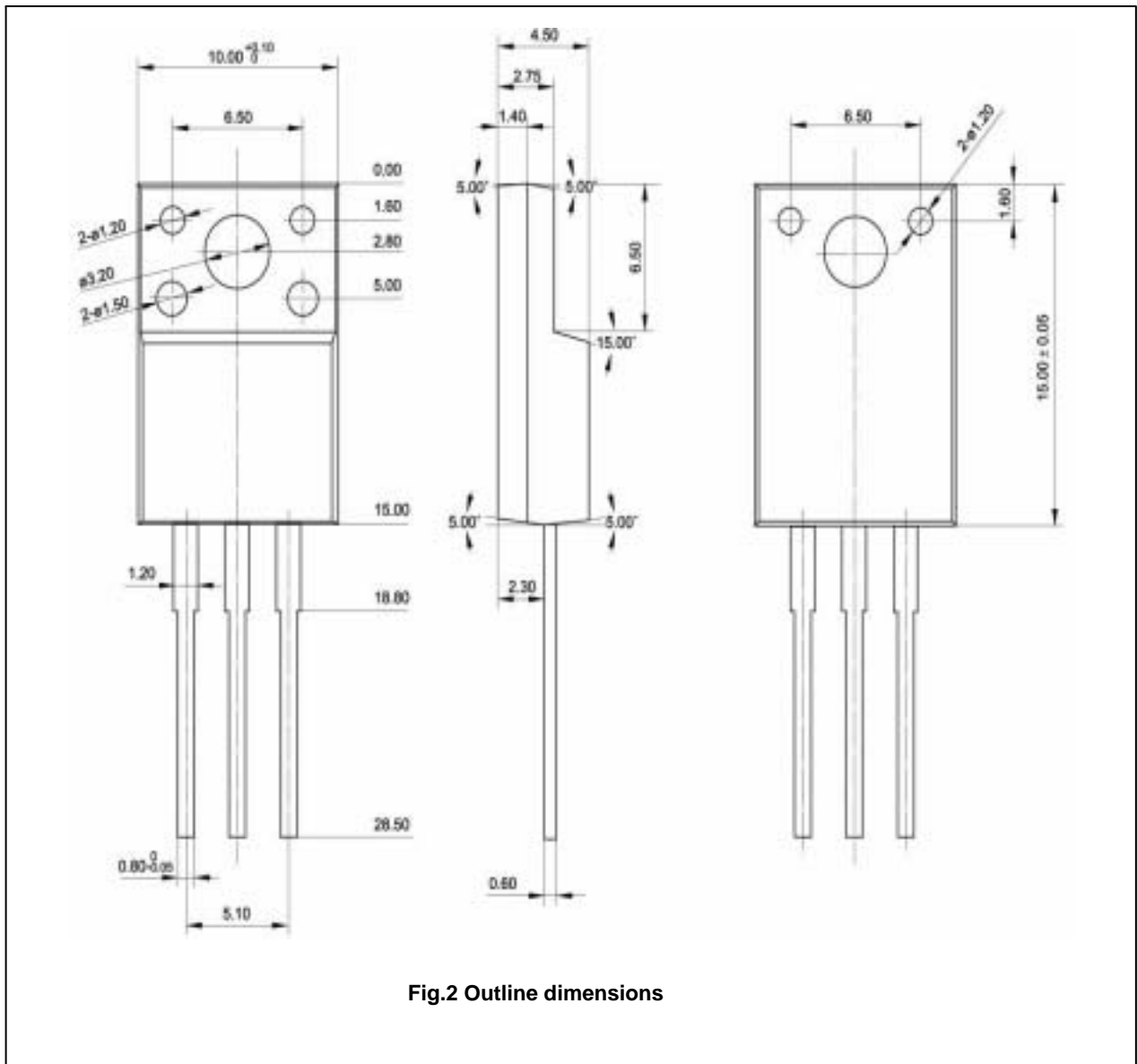

Fig.2 Outline dimensions